

EMERGENCY RESCUE DEVICE 3kW V.2



QUICK START GUIDE

VERSION 1.0



Document History

Date	Version	Summary of Changes
January 10, 2025	1.0	Initial Release

1 Emergency Rescue Device 1

2 Charging the ERD 2

3 Components 2

 3.1 Battery Disconnect Switch 2

 3.2 Contactors 2

 3.3 Enclosure and Heatsink 2

 3.4 Battery 2

 3.5 DIP Switches 3

 3.6 Push Button 3

4 ERD Wiring 3

5 Layout 4

6 Sequence of Operation 4

7 Safety 5

 7.1 Important Safety Instructions 5

 7.2 Disposal 6

8 Battery Removal and Replacement 6

9 Troubleshooting Tips 8

10 Specifications 10

Figure 1: Emergency Rescue Device 1
Figure 2: Power Switch – ON..... 2
Figure 3: KEB ERD Sample External Wiring..... 3
Figure 4: ERD Layout..... 4
Figure 5: Power Switch – OFF 6
Figure 6: Battery Replacement 7
Figure 7: ERD LEDs 9

Page intentionally left blank.

1 Emergency Rescue Device

The Smartrise Emergency Rescue Device (ERD) is a battery backup system designed to supply emergency power during a mainline power outage. The ERD continuously monitors the mainline for power loss. Upon detecting a power outage, the ERD isolates the elevator from the mainline and generates enough power to move the elevator to the nearest floor in the pre-selected direction. Once there, it opens the doors to ensure the safe rescue of trapped passengers.

The ERD operates with two key contactors:

- ◆ **P:** This contactor remains picked during normal elevator operation. Upon detecting a power loss, the contactor opens, isolating the elevator from the mainline.
- ◆ **Q:** This contactor is picked only during the rescue operation when the P contactor is open.

Communication between the ERD and the elevator controller is facilitated through three discrete signals:

- ◆ **Out3:** During rescue mode, a UPS mode signal is sent from the controller to the drive, acknowledging that the system is in rescue mode.

NOTE: Out3 and Out2 pick simultaneously.

- ◆ **Out2:** When a power loss is detected, this signal notifies the controller that the rescue process has begun.
- ◆ **Out1:** If an ERD fault occurs, such as a low battery, this signal notifies the controller of the ERD failure.

The ERD also features a mainline disconnect safety function. When the mainline disconnect switch (provided separately) is turned off, the **ML1 – ML2** circuit opens, preventing the ERD from activating.

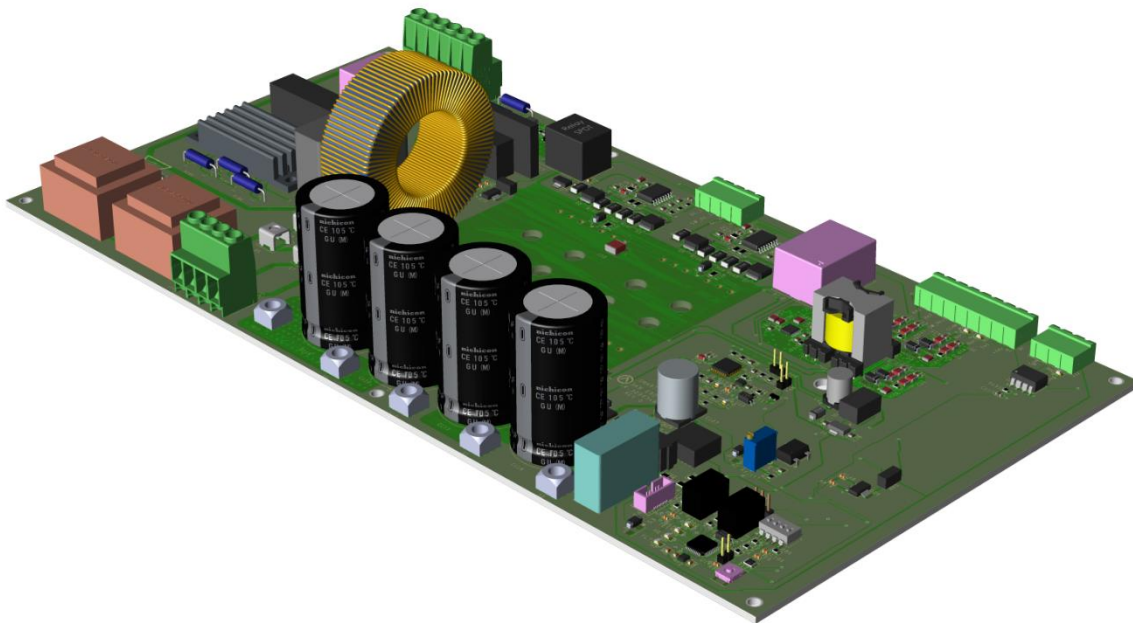

Figure 1: Emergency Rescue Device

2 Charging the ERD

For the ERD to operate, its batteries must be charged. To charge the batteries, ensure that the ERD switch is in the **ON** position.

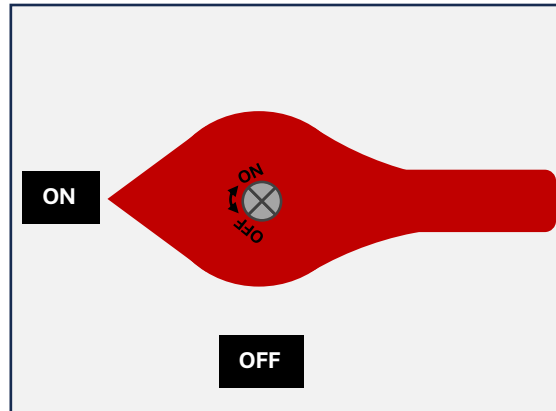

Figure 2: Power Switch – ON

3 Components

This section consists of the components present on the ERD.

3.1 Battery Disconnect Switch

The Battery Disconnect switch features a Switch Guard.

3.2 Contactors

The ERD contains two contactors:

- ◆ **P:** 48 VAC coil
- ◆ **Q:** 48 VDC coil

3.3 Enclosure and Heatsink

The enclosure and heatsink are custom-made.

3.4 Battery

- ◆ **Battery Type:** Zeus PC20-12M-5 (12V20AH)
- ◆ **Number of Batteries:** 4 (connected in series)
- ◆ **Nominal Voltage of Total Battery String:** 48V
- ◆ **Nominal Capacity of Total Battery String:** 20AH

3.5 DIP Switches

- ◆ **DIP 1:** Manual Battery Output (10 seconds)
- ◆ **DIP 2:** Not used
- ◆ **DIP 3:** Not used
- ◆ **DIP 4:** Single Phase / Three Phase Fault Detection

NOTE: All four DIP switches are set to OFF by default.

3.6 Push Button

- ◆ **Reset:** Resets the board.

4 ERD Wiring

Below is an example of the wiring for the ERD.

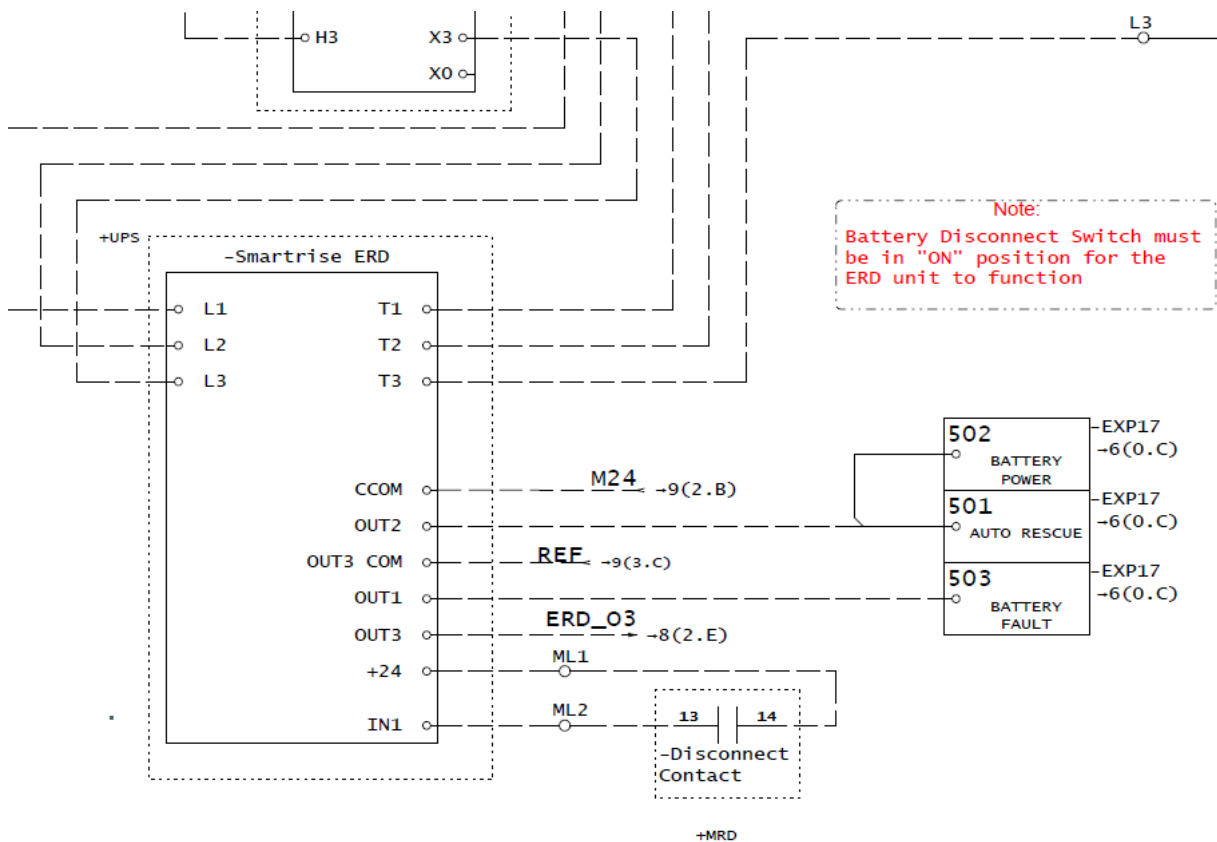

Figure 3: KEB ERD Sample External Wiring

CAUTION: To minimize the risk of fire, ensure the ERD is connected to a circuit equipped with a maximum 140-ampere branch circuit overcurrent protection, as specified by the National Electrical Code (ANSI/NFPA 70). The ERD must be connected exclusively to a dedicated branch circuit.

5 Layout

The image below shows the ERD layout.

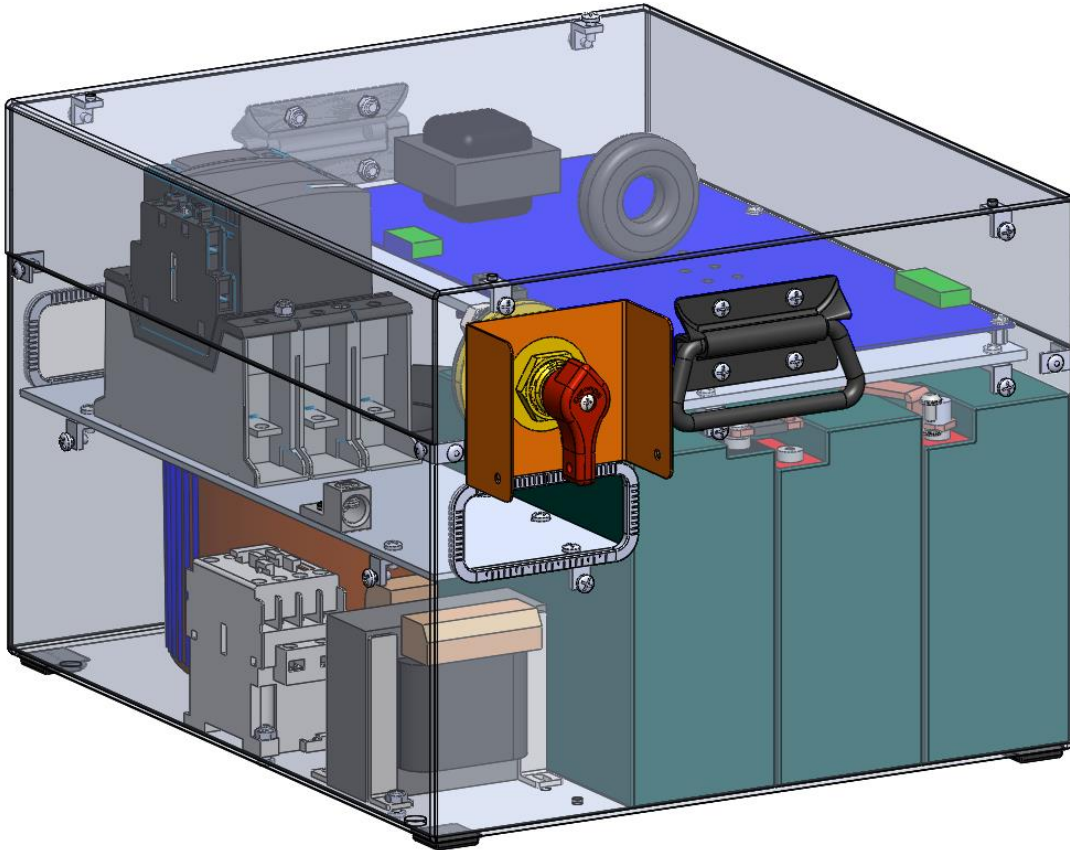

Figure 4: ERD Layout

6 Sequence of Operation

The following describe the ERD's operational sequence:

1. The ERD continuously monitors the mainline for power loss.
2. Upon detecting a power loss, the **Out2** and **Out3** outputs activate, signalling the controller and drive that the ERD is about to start.
3. After a two-second delay, the **P contactor** drops, isolating the elevator from the mainline.
4. Following another eight-second delay, the **Q contactor** picks, connecting the controller to the ERD power.
5. After 10 seconds, the ERD begins supplying sufficient power to move the elevator car.
6. The controller determines the easiest direction to move and initiates movement in that direction.
7. Once the car reaches the nearest floor and the doors open, the controller transitions to idle mode.
8. After five minutes, the ERD cuts the power to the controller and remains in standby until the mainline power is restored.

9. When the mainline power is restored, the **P contactor** picks, connecting the main line power to the controller, the **Q contactor** drops, and the **Out2** and **Out3** outputs deactivate.
10. The ERD returns to idle mode and resumes charging the batteries.

7 Safety

IMPORTANT: Follow the safety precautions closely when removing or replacing batteries to prevent injury or equipment damage:

CAUTION: Risk of explosion if a battery is replaced with an incorrect type.

CAUTION: A battery can present a risk of electrical shock and high short-circuit current.

CAUTION: Do not disconnect the battery while it is under a load condition.

7.1 Important Safety Instructions

The following precautions are important and must be followed when working with batteries during installation and maintenance.

SAVE THESE INSTRUCTIONS for future reference.

1. Battery servicing must be performed or supervised by personnel knowledgeable in battery systems and safety precautions.
2. Remove all metal objects, such as watches, rings, or jewelry, before working with batteries.
3. Use tools with insulated handles to avoid electrical contact.
4. Wear rubber gloves and boots for protection.
5. Do not place tools or metal objects on top of the batteries.
6. Disconnect the charging source before connecting or disconnecting battery terminals.
7. Verify whether the battery is mistakenly grounded. If so, remove the grounding source. Contact with a grounded battery can cause electrical shock. This risk can be minimized by removing the ground during installation and maintenance.
8. Replace batteries only with sealed lead-acid batteries rated at 12 VDC each.
9. Do not open or damage batteries. The electrolyte inside is harmful to the skin and eyes and can be toxic.

Maximum ambient temperature rating: 104°F (40°C). The ERD is intended for use in a controlled environment.

Use in restricted-access areas only.

A 4-pole or 3-pole with one auxiliary mainline disconnect switch must be installed on the controller.

7.2 Disposal

Dispose of used batteries in accordance with local regulations.

CAUTION: Do not dispose of batteries in a fire, as they may explode.

8 Battery Removal and Replacement

This section provides important instructions to be followed during the installation and maintenance of the ERD unit.

NOTE: Battery servicing should be performed or supervised by personnel knowledgeable in batteries and the necessary precautions.

The batteries in the ERD are rechargeable, but they will eventually need replacement.

Batteries must be replaced with Zeus PC20-12M-5 (12V20AH) or an equivalent model.

WARNING

Reversing the polarity of the battery terminals may cause damage to the equipment.

CAUTION: Risk of explosion if the battery is replaced with an incorrect type.

CAUTION: Do not open or mutilate the batteries. Released electrolytes are harmful to the skin and eyes and can be toxic.

The following steps outline how to properly remove and replace a battery:

1. Disconnect main power to the ERD.
2. Turn the battery disconnect switch to the **OFF** position.

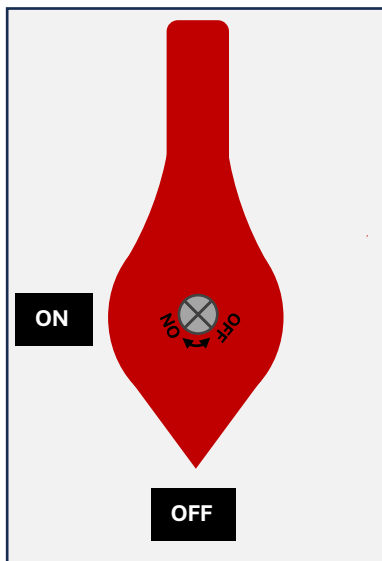

Figure 5: Power Switch – OFF

3. Open the ERD cabinet.
4. Remove screws, lock washers, washers, and nuts from the power and ground cables.
5. Move the power and ground cables away from the battery set and cabinet.

CAUTION: Risk of explosion if battery is replaced by an incorrect type. Dispose of used batteries according to the instructions.

6. Remove the screws and battery cable from both sides of the batteries.
7. Remove the nuts, lock washers, and washers from the top bracket.
8. Slide out the side containing the faulty battery from the cabinet.
9. Remove the screws and bus bar connecting the two batteries.
10. Remove and replace the faulty battery.



Figure 6: Battery Replacement

11. Reinstall the screws and battery cable to secure the replacement battery.
12. Slide the battery assembly back into the cabinet.
13. Secure the top bracket with washers, lock washers, and nuts.
14. Reinstall the screws and the battery cable, ensuring both sides of the batteries are properly connected, and the bus bar is secured.
15. Reposition the power and ground cables onto the battery terminals.
16. Reinstall and secure the nuts, washers, lock washers, and screws on the battery power and ground cables.
17. Turn the battery disconnect switch back to the **ON** position.

18. Close the ERD cabinet.
19. Restore power to the ERD.
20. Dispose of the faulty battery in accordance with local regulations.

9 Troubleshooting Tips

Perform the following checks if the ERD does not power on when the main line is disconnected:

- ◆ Ensure the ERD disconnect switch is in the **ON** position.
- ◆ Verify that the measured values of **BAT+** and **BAT-** are approximately **48 VDC**.
- ◆ Confirm that the measured values of **T1** and **T2** match the mainline voltage on the ERD board.
- ◆ Ensure the battery is connected properly.
- ◆ Inspect the outgoing wiring to the control transformer.
- ◆ Check if the **150 A** fuse is blown.
- ◆ Check if the **2.5 A** fuse on **F2** is blown.
- ◆ Ensure that the **P contactor** is open and the **Q contactor** is closed.
- ◆ Verify that **IN1** and **O24** are in the **NC (Normally Closed)** position.
- ◆ While the ERD is outputting, turning the AC Out potentiometer clockwise increases the AC Out voltage, while turning it counterclockwise decreases the AC Out voltage.

The table below lists and describes the different types of faults that may be encountered.

Fault Type	Blink Cycle	Board Type	Description
Low Battery	Solid	ERD 3kW	Triggered when the battery voltage falls below the low voltage threshold while not outputting.
AC Out Fault Input	Solid	ERD 3kW	Activated when the AC Out Fault LED is off while the ERD is outputting.
Rescue Timeout	150ms	ERD 3kW	For ERD boards, triggered when the rescue power (outputting state) reaches the five-minute timeout.
Low Battery	Solid	ERD 3kW	Triggered when the battery voltage falls below the low voltage threshold while not outputting.

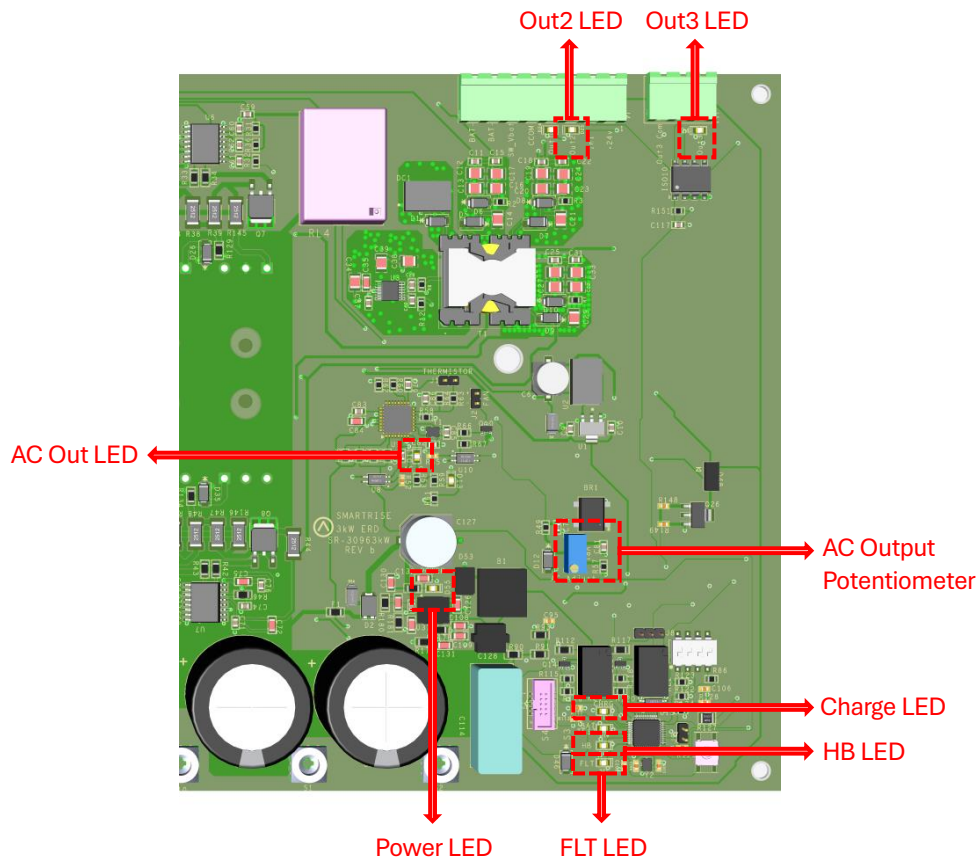

Figure 7: ERD LEDs

Expected LED behavior during rescue operation:

- ◆ **Heartbeat (HB) LED:** Flashes green to indicate system activity.
- ◆ **Fault (FLT) LED:** Flashes in cycles to indicate the system's state and any faults detected in the ERD.
- ◆ **Power LED:** Displays solid green to indicate the system is powered on.
- ◆ **AC Out LED:** Displays solid red to indicate AC output status.
- ◆ **Out3 LED:** Displays solid green when active.
- ◆ **Out2 LED:** Displays solid orange when active.

10 Specifications

The table below lists the power rating specifications for the ERD:

Specification	Value
Charge Mode	
AC Input Voltage	208/ 240/ 480 VAC
Input Frequency	60 Hz
Input Current	350 mA/ 300 mA/ 150 mA max
DC Input (From External Battery Pack)	48 VDC nominal, 20 AH
DC Output (To External Battery Pack - Charge)	53 VDC nominal, 1.5 A max
AC Output Voltage	208/ 240/ 480 VAC
Output Frequency	60 Hz
Output Power	150 VA / 150 W
Inverter Mode	
DC Input (From External Battery Pack)	48 VDC nominal, 20 AH
DC Output (To External Battery Pack - Charge)	48 VDC nominal, 7 A max
AC Output Voltage	208, 240, 480 VAC
Output Frequency	60 Hz
Output Power	3 KW

The table below lists the dimensions and weight of the ERD:

Specification	Value
Size of Unit	15.5" x 13.5" x 10.25"
Weight of Unit	85 lbs