

BATTERY LOWERING DEVICE V.2

→ QUICK START GUIDE ←

VERSION 1.0



Document History

Date	Version	Summary of Changes
January 3, 2025	1.0	Initial Release

1	Smart Battery Lowering Device	1
2	Turning On the BLD	3
3	Components	3
3.1	Terminals	3
3.2	LEDs	3
3.3	DIP Switches	5
3.4	Push Button	5
3.5	J7 NO/NC BLD Configuration	5
3.6	Wiring Based on Main Line Voltage.....	6
4	Testing Procedure	7
5	Smart Battery Lowering Device Wiring.....	9
6	Safety.....	10
6.1	Important Safety Instructions	10
6.2	Disposal	10
7	Battery Removal and Replacement.....	11
8	Troubleshooting Tips	12
9	Specifications.....	13

Figure 1: Battery Lowering Device.....	1
Figure 2: Battery Lowering Device - Labels	2
Figure 3: Power Switch - ON	3
Figure 4: Power Switch - OFF.....	3
Figure 5: BLD LEDs	4
Figure 6: 208 VAC Wiring.....	6
Figure 7: 240 VAC Wiring.....	6
Figure 8: 480 VAC Wiring.....	6
Figure 9: Smart Battery Lowering Device 480 VAC Wiring	9
Figure 10: Screw Locations.....	11

Page intentionally left blank.

1 Smart Battery Lowering Device

In the event of a power loss, the Smart Battery Lowering Device (BLD) will move the elevator to the nearest floor and open the doors.

WARNING

DO NOT TOUCH THE BOARD WHILE THE BATTERY LOWERING OPERATION IS IN PROCESS DUE TO HIGH VOLTAGE. AFTER THE UNIT SHUTS DOWN, WAIT FOR 2 MINUTES TO ALLOW THE CAPACITORS TO FULLY DISCHARGE.

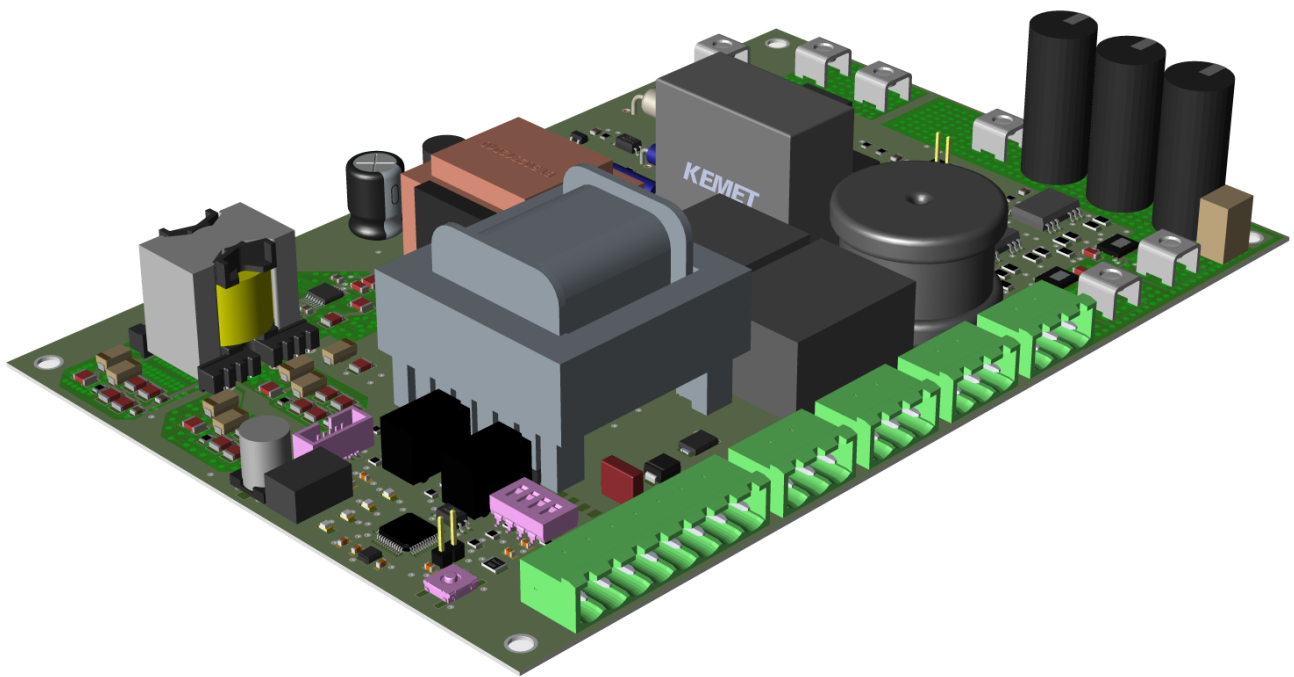

Figure 1: Battery Lowering Device

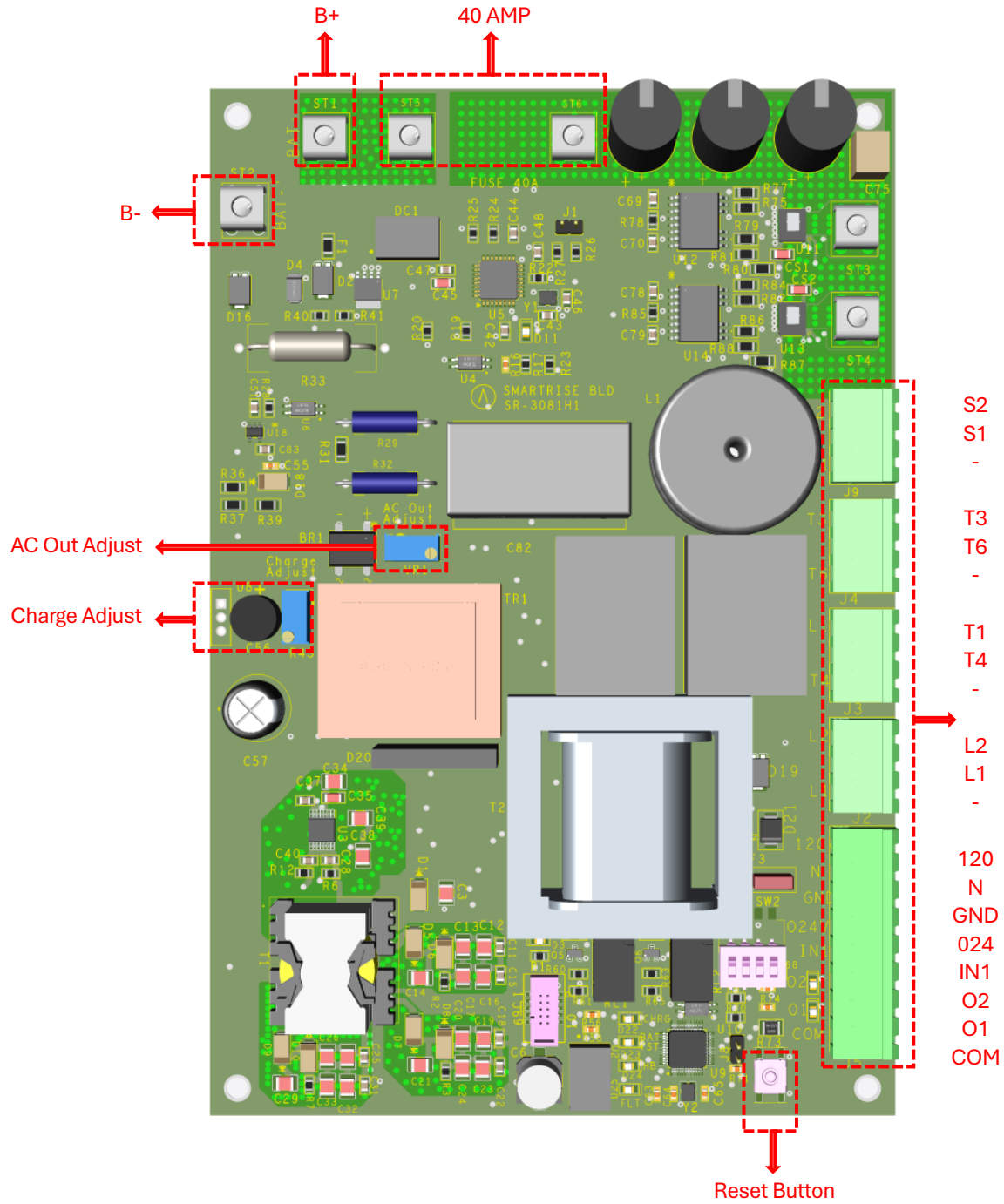

Figure 2: Battery Lowering Device - Labels

2 Turning On the BLD

Ensure the batteries in the BLD are charged and the switch is in the **ON** position. The batteries will continue charging as long as the **120** and **N** terminals are connected to **120 VAC** and the BLD is not outputting power.

NOTE: If the power switch is in the **OFF** position or the battery voltage is low, the FLT (fault) output will activate.

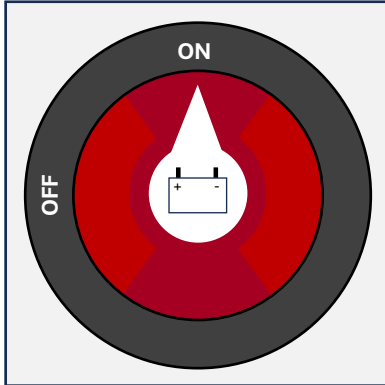

Figure 3: Power Switch - ON

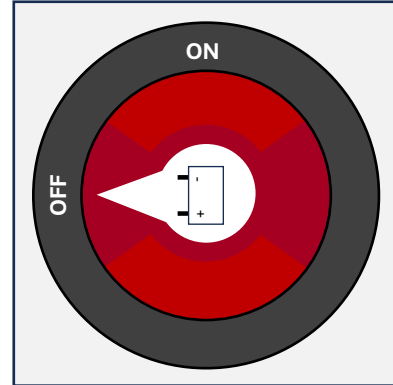

Figure 4: Power Switch - OFF

3 Components

This section consists of the components present on the BLD.

3.1 Terminals

The terminals on the BLD, along with their descriptions, are outlined below:

- ◆ **L1, L2 – L1, L2 from Main Line:** Connected to the main line and detects main power loss.
- ◆ **L1, T4, T3, T6:** External connections based on incoming main line power [see Figure 6, Figure 7, and Figure 8].
- ◆ **120, N: 120 VAC –** charges the batteries.
- ◆ **O24, IN1:** Main line auxiliary switch.
- ◆ **O2:** Battery lowering input to the controller.
- ◆ **O1:** Battery lowering fault input to the controller.
- ◆ **COM:** 24 VDC from the controller.
- ◆ **NC/NO Jumper:** Refer to section 3.5 J7 NO/NC BLD Configuration.

3.2 LEDs

The LEDs on the BLD, along with their descriptions, are outlined below:

- ◆ **FLT:** Indicates a 'low battery' fault.

- ◆ **HB:** Indicates power is on and the BLD is operational.
- ◆ **Charge:** Solid indicates the battery is charging.
- ◆ **Test LED:** Indicates testing when DIP 3 is turned ON.
- ◆ **FLT LED:** Flashes in cycles to indicate the state and any faults in the BLD [see Figure 5].
- ◆ **O1 LED:** Indicates a BLD fault.
- ◆ **O2 LED:** Indicates that the BLD is outputting and operating in rescue mode.
- ◆ **Power LED:** Solid LED indicates that the BLD is operational.
- ◆ **AC OUT LED:** Indicates that the EG8010 is operational.

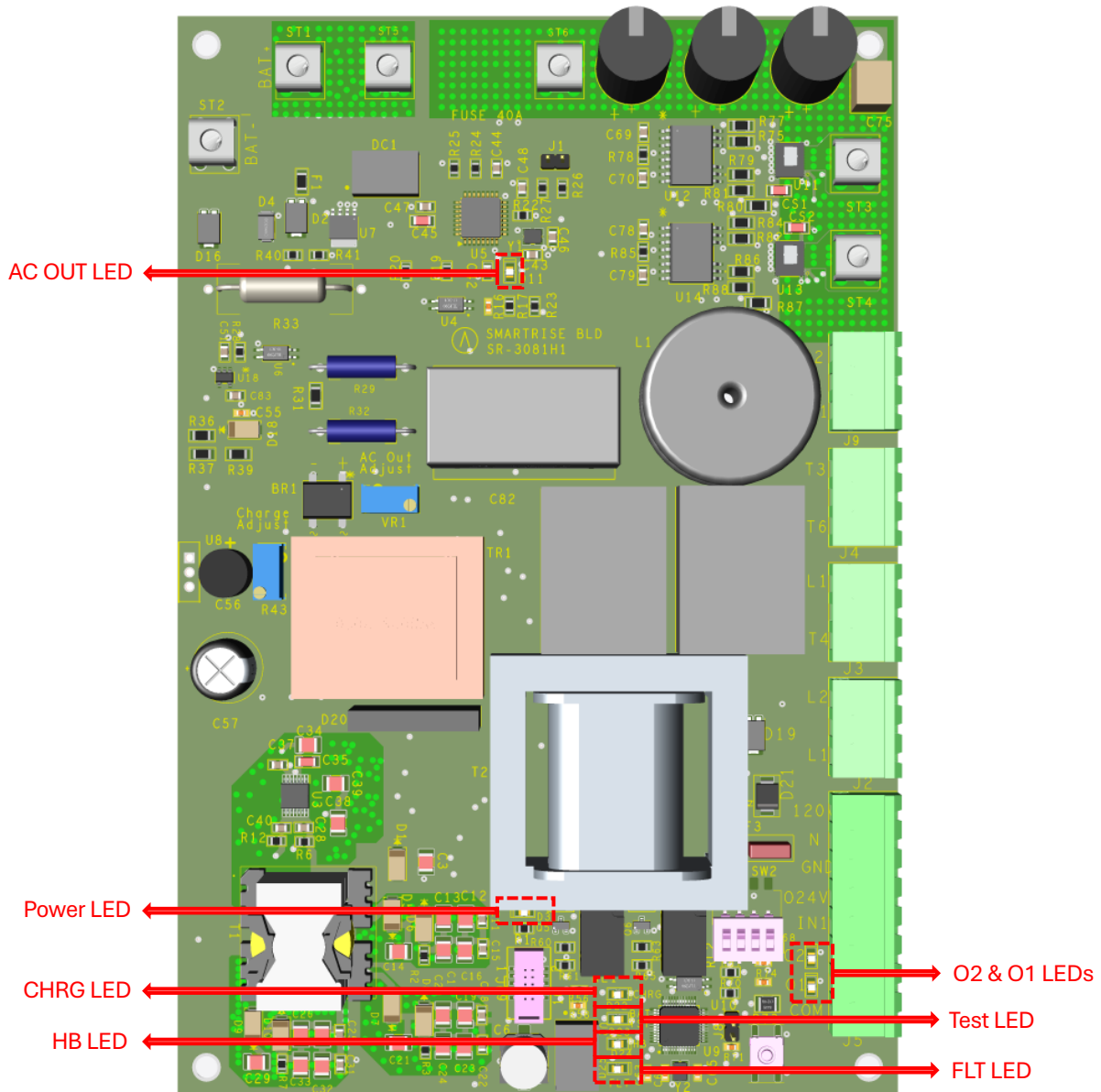

Figure 5: BLD LEDs

3.3 DIP Switches

- ◆ **DIP 1:** Manual Battery Output (5 seconds)
- ◆ **DIP 2:** Not used
- ◆ **DIP 3:** Manual Battery Test (LED C indicates test)
- ◆ **DIP 4:** Not used

NOTE: All four DIP switches are set to OFF by default.

3.4 Push Button

- ◆ **Reset:** Resets the board.

3.5 J7 NO/NC BLD Configuration

- ◆ **NO:** C4 Hydro:Evolved, C4 Traction, V2 Traction.
- ◆ **NC:** V2 Hydro.

3.6 Wiring Based on Main Line Voltage

The Battery Lowering Device can be configured to operate with 208 VAC, 240 VAC, or 480 VAC main line power.

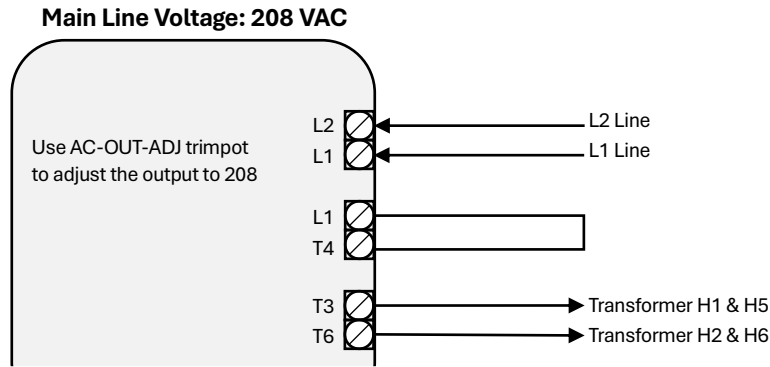

Figure 6: 208 VAC Wiring

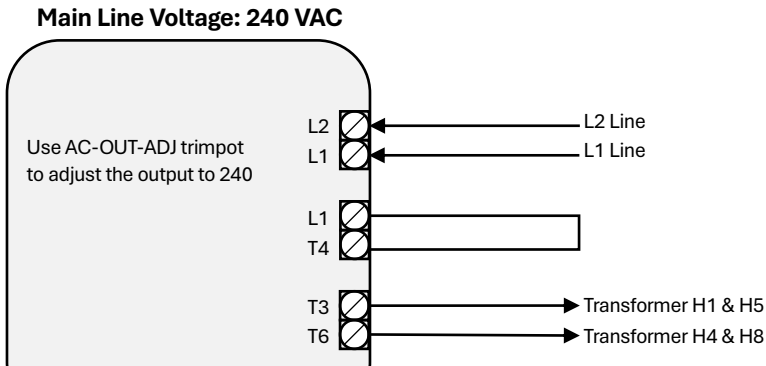

Figure 7: 240 VAC Wiring

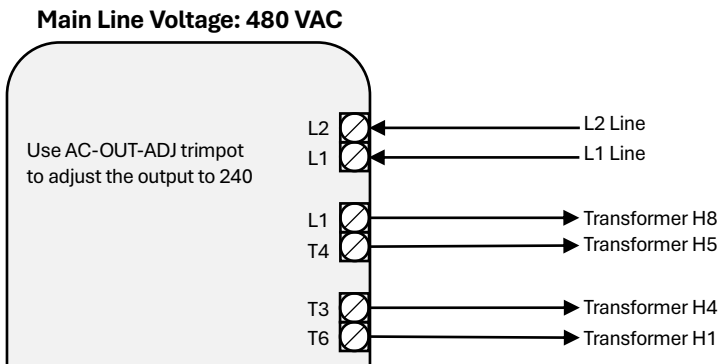

Figure 8: 480 VAC Wiring

4 Testing Procedure

WARNING

DO NOT TOUCH THE BOARD WHILE THE MAIN POWER IS ON OR THE BLD IS IN OPERATION.

Pre-Test Requirements:

Before powering up the BLD, perform the following checks:

1. Verify continuity between the following points:
 - ST1 to GND
 - ST2 to GND
 - ST3 to GND
 - ST4 to GND.

NOTE: There should be no continuity (no beep).

2. Ensure the GND terminal on the BLD connector is properly wired to the controller GND.

Test Procedure:

Follow these steps to test the BLD:

1. Turn on the main line power.
2. Set the battery switch to the **ON** position.
3. Observe the **Power**, **HB**, **Charge**, and **Fault** LEDs. All should illuminate initially.
4. Wait for 10 seconds; the **Fault** LED should turn off. If it does not turn off, press the reset button.
5. Turn off the battery switch.
6. Measure the DC voltage between **ST2** and **ST6** while pressing the reset switch. The reading should be between **28 – 32 VDC**.

NOTE: If the voltage falls outside the range, adjust the charging potentiometer to **31 – 32 VDC** while keeping the reset switch pressed.

7. Once the voltage is confirmed, reverse the previous steps.
8. Turn off the main line. Within three seconds, the BLD should activate if **IN1** and **O24** are jumped (NC).
9. Confirm that the **D11**, **HB**, **Power**, and **O2** LEDs are on.

NOTE: The **O1** LED should remain off. If it turns on, the BLD has detected a fault.

10. During the test, adjust the AC output potentiometer to match the main line AC voltage. Measure the AC voltage on **T3** and **T6** of the BLD connector.

NOTE: The maximum AC output voltage is **240 VAC** for both **240 VAC** and **480 VAC** main lines.

11. During the rescue operation, measure the battery DC voltage between **ST1** and **ST2**. The voltage should decrease slowly under load and should not drop rapidly.

NOTE I: If the battery voltage decreases rapidly, the battery may lack sufficient charge capacity and require charging or replacement.

NOTE II: If the battery voltage falls to **19 VDC** during rescue, the BLD will automatically turn off due to low voltage.

12. Once the rescue operation is completed, the battery will remain in idle mode for 10 minutes before the battery power turns off to preserve voltage. The **Fault** LED will then continue to blink every 300ms.
13. The **O1** LED may remain on even after the main line power is restored. This behavior is consistent with the **Fault** LED functionality. For example, if a Low Battery condition is detected while the main line power is on, both the **Fault** and **O1** LEDs will illuminate and remain solid.
14. When the BLD detects main line power, it will switch back to normal operation.

NOTE: The **D11** and **O2** LEDs will turn off, while the **Power**, **Charge**, and **HB** LEDs remain on.

5 Smart Battery Lowering Device Wiring

Below is an example of the wiring for the Smart BLD.

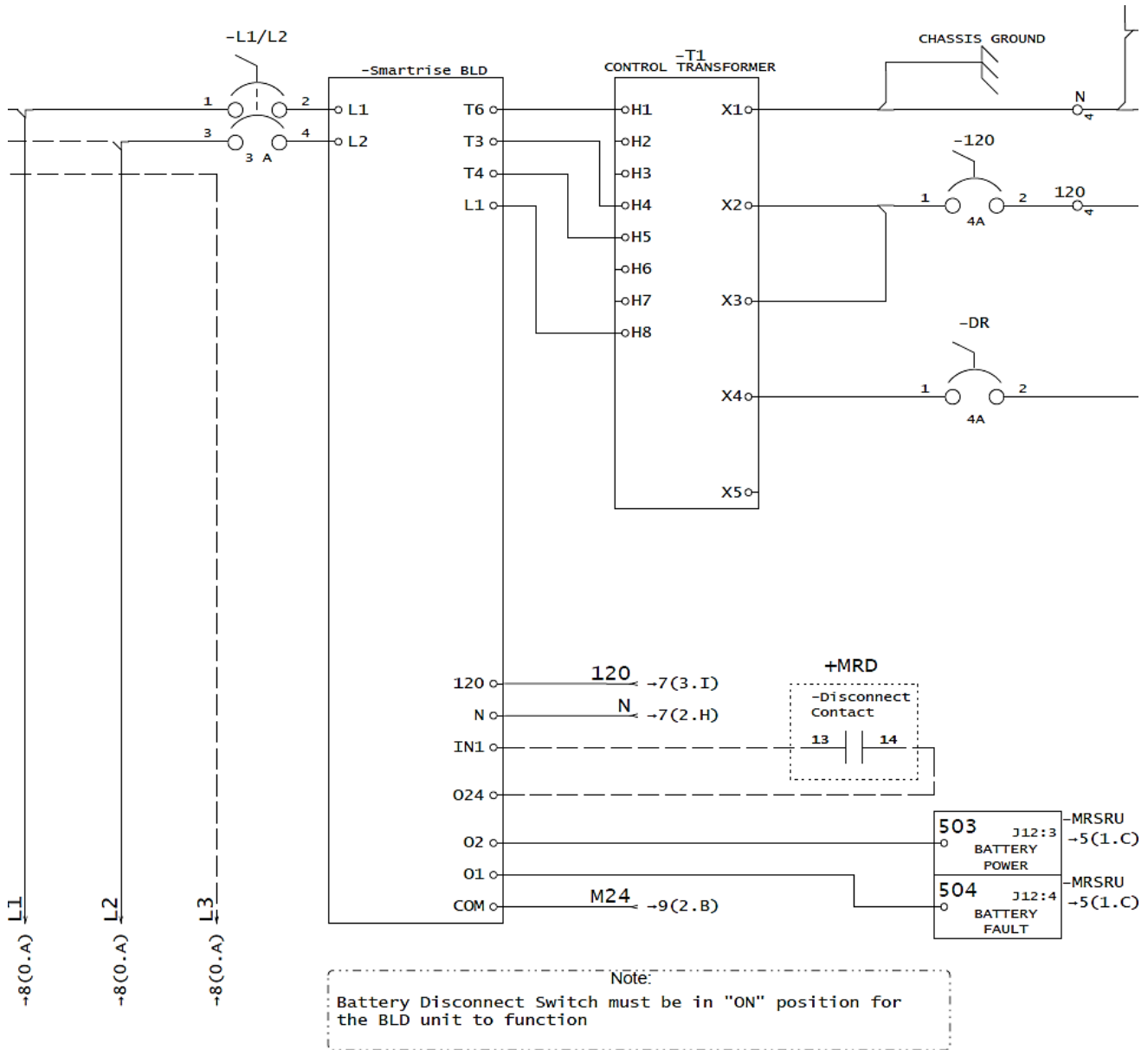

Figure 9: Smart Battery Lowering Device 480 VAC Wiring

6 Safety

IMPORTANT: Follow the safety precautions closely when removing or replacing batteries to prevent injury or equipment damage:

CAUTION: Risk of explosion if a battery is replaced with an incorrect type.

CAUTION: A battery can present a risk of electrical shock and high short-circuit current.

CAUTION: Do not disconnect the battery while it is under a load condition.

6.1 Important Safety Instructions

The following precautions are important and must be followed when working with batteries during installation and maintenance.

SAVE THESE INSTRUCTIONS for future reference.

1. Battery servicing must be performed or supervised by personnel knowledgeable in battery systems and safety precautions.
2. Remove all metal objects, such as watches, rings, or jewelry, before working with batteries.
3. Use tools with insulated handles to avoid electrical contact.
4. Wear rubber gloves and boots for protection.
5. Do not place tools or metal objects on top of the batteries.
6. Disconnect the charging source before connecting or disconnecting battery terminals.
7. Verify whether the battery is mistakenly grounded. If so, remove the grounding source. Contact with a grounded battery can cause electrical shock. This risk can be minimized by removing the ground during installation and maintenance.
8. Replace batteries only with sealed lead-acid batteries rated at 12 VDC 6AH each.
9. Do not open or damage batteries. The electrolyte inside is harmful to the skin and eyes and can be toxic.

Maximum ambient temperature rating: 104°F (40°C). The BLD is intended for use in a controlled environment.

Use in restricted-access areas only.

A 4-pole mainline disconnect switch or auxiliary dry contact must be provided and installed.

6.2 Disposal

Dispose of used batteries in accordance with local regulations.

CAUTION: Do not dispose of batteries in a fire, as they may explode.

7 Battery Removal and Replacement

This section provides important instructions to be followed during the installation and maintenance of the BLD unit.

NOTE: Battery servicing should be performed or supervised by personnel knowledgeable in batteries and the necessary precautions.

The batteries in the BLD are rechargeable, but they will eventually need replacement.

Batteries must be replaced with Yuasa Genesis NPX-25 or an equivalent model.

WARNING

Reversing the polarity of the battery terminals may cause damage to the equipment.

CAUTION: Risk of explosion if the battery is replaced with an incorrect type.

CAUTION: Do not open or mutilate the batteries. Released electrolytes are harmful to the skin and eyes and can be toxic.

The following steps outline how to properly remove and replace a battery:

1. Disconnect main power to the BLD.
2. Open the BLD cabinet.
3. Turn off the battery disconnect switch.
4. Remove the screws located at the four corners to access the batteries.

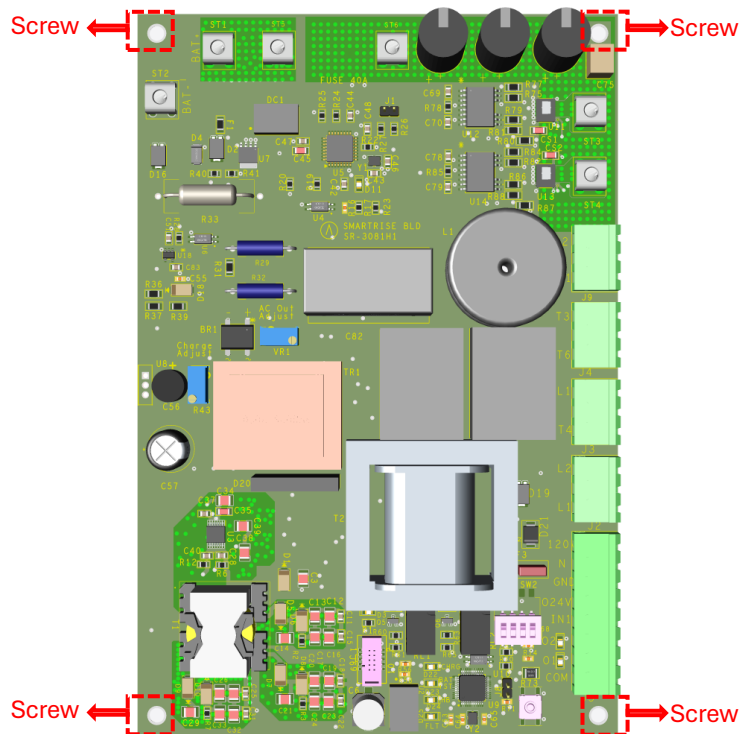

Figure 10: Screw Locations

5. Remove the screws from ST1 and ST2.
6. Remove screws, lock washers, washers, and nuts from the power and ground cables.
7. Move the power and ground cables away from the battery set and cabinet.

CAUTION: Risk of explosion if battery is replaced by an incorrect type. Dispose of used batteries according to the instructions.

8. Remove and replace the bad batteries.
9. Reinstall the nuts, washers, lock washers, and screws, and reconnect the power and ground cables.
10. Close the BLD cabinet.
11. Restore power to the BLD.
12. Dispose of the old battery according to local regulations.

8 Troubleshooting Tips

Perform the following checks if the BLD does not power on when the main line is disconnected:

- ◆ Check that the BLD disconnect switch is in the **ON** position (**SW1** and **SW2** should show a short on the battery connector).
- ◆ Check the continuity between **O24** & **IN1**.
- ◆ **BAT+** and **BAT-** should measure **26 – 28 VDC** for fully charged batteries with the battery connector connected to the board.
- ◆ **T3** and **T6** should measure the same as the main line voltage.
- ◆ Verify that there is **120 VAC** between terminals **120** and **N** for battery charging (charging will occur regardless of the BLD disconnect switch position) and that there is **28 – 32 VDC** while the reset button is pressed.
- ◆ Check that the **40A** fuse is not blown.
- ◆ Ensure proper incoming main line voltage.
- ◆ Verify proper outgoing wiring to the control transformer.
- ◆ Check for **24 VDC** from the controller at terminal **COM**.
- ◆ Ensure correct battery connections.
- ◆ Monitor the flashing red LED code on the SR-3081H1 board [see Figure 5].

9 Specifications

The table below lists the power rating specifications for the BLD:

Specification	Value
Charge Mode	
AC Input Voltage	120 VAC
Input Frequency	60 Hz
Input Current to Charging Transformer	500 mA max
Output Charging Current to Batteries	750 mA max
Charging Transformer Output Power	6 VA
DC Out to Batteries Pack Charge	32 VDC Max
Inverter Mode	
DC Input (From External Battery Pack)	20 VDC – 28 VDC
AC Output Voltage	240 VAC
AC Output Frequency	60 Hz
Output Power	500 W

The table below lists the dimensions and weight of the BLD:

Specification	Value
Size of Unit	8.5" x 5.75" x 7.5"
Weight of Unit	19.5 lbs